

⚠ CAUTION

- Wear safety glasses when operating the electric drill or rivet gun.
- Make sure anyone installing this product has read and understands these instructions.

Required Tools

- Electric drill with 1/8" drill bit (to remove old rivets)
- Rivet gun (to install using rivets)
- Electric screwdriver or drill with phillips head bit (to install using screws)

Parts List

Item	Qty	Description
1	1	Front Bumper
2	3*	1/8" (0.125 mm) Dia Blind Rivet, Grip 0.188/0.25
3	3*	8-18 x 1/2" Phillips Head Self-tapping Screw

*Only two Rivets or Screws needed.
There is a spare of each included.

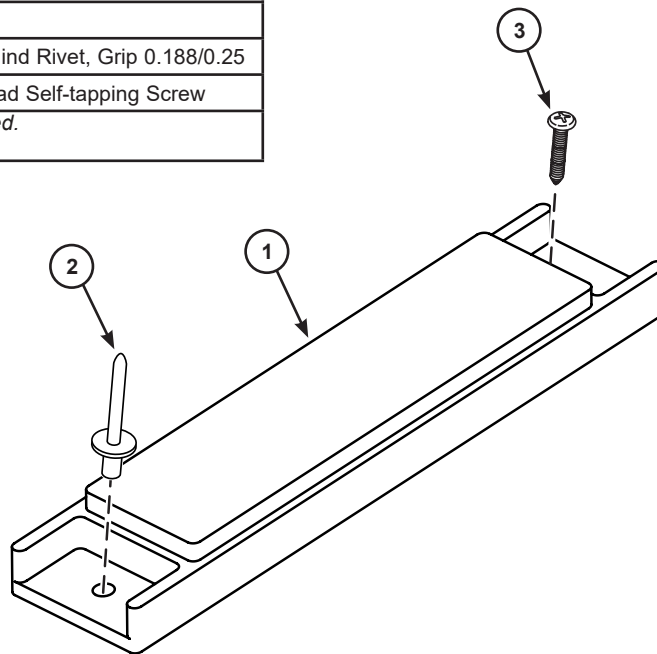

Visit the Nota Chairs web page at wengercorp.com for more information.

Note: Please read and understand these instructions before proceeding.

Note: If you need additional information, contact Wenger Corporation using the information below.

Front Bumper Replacement

1. If the old front bumper and rivets need to be removed, drill out the old rivets or rivet remnants with an electric drill fitted with an 1/8" drill bit.
2. Place the front bumper over the front two center holes in the frame on the bottom of the chair.

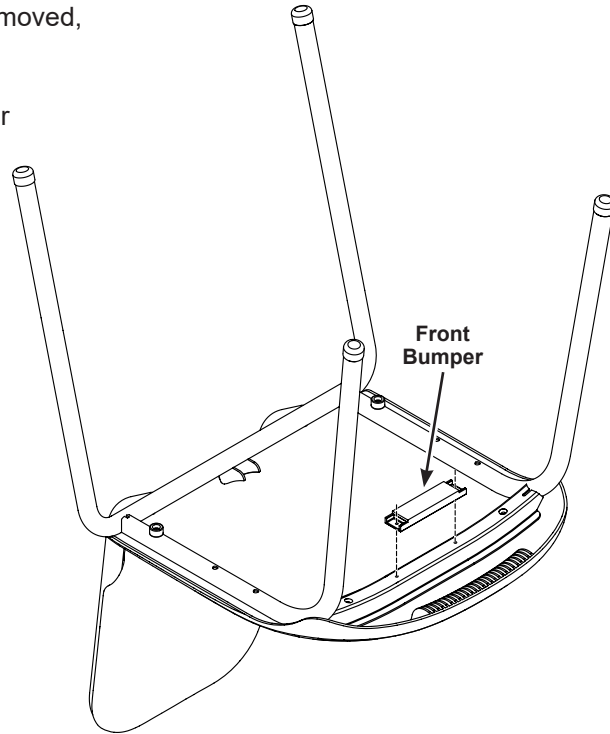

3. Secure the front bumper to the frame using either two rivets or two screws.

